

Pizza Prep Tables

Exceptional Quality 2 Years Parts and Labor Warranty



TPR-44SD



TPR-67SD



TPR-93SD

≡ FEATURES / BENEFITS ≡

■ EFFICIENT REFRIGERATION SYSTEM

Turbo Air's solid door refrigerators are designed with oversized and balanced (CFC Free R-134A) refrigeration systems. These include efficient evaporators and condensers for faster cooling and greater efficiency.

■ EXCELLENT COOLING SYSTEM

The powerful forced-air refrigeration system maintains the storage cabinet at a constant temperature. The evaporator fan and a newly designed stainless steel louver allow uniform distribution of cold air over the food pans and throughout the unit to keep food temperature within the NSF standard 7 requirements.

■ STAINLESS STEEL CABINET CONSTRUCTION

The Turbo Air Super Deluxe model boasts a stainless steel interior and exterior. It guarantees the utmost in cleanliness and long product life. ABS sheet door liners resist water condensation with thermal efficiency. The Super Deluxe can add a touch of style to the most refined setting.

■ HIGH-DENSITY POLYURETHANE INSULATION

The entire cabinet structure and solid doors are formed-in-place using high density, CFC free polyurethane insulation.

■ STURDY, CLEAN STAINLESS SHELVING

Shelves are the most important part of cleanliness as they come in direct contact with food. After a while, PVC coated wire shelves may peel, rust and lead to unsanitary conditions. Only the Turbo Air Super Deluxe series uniquely provides stainless shelving.

■ ERGONOMICALLY DESIGNED DOOR

Customers' fatigue fades away with easy grip handles and doors that open effortlessly. These features self-closing doors make this the ultimate choice in quality and customer convenience. ABS sheet door liners resist water condensation with thermal efficiency.

■ MAGNETIC DOOR GASKET

Magnetic door gaskets are of one piece construction, removable without tools for ease of cleaning and replacement.

■ EXTRA DEEP CUTTING BOARD

Our cutting board is 19-1/2" deep to provide ample working space, and is made of easy to sanitize polyurethane. The new side rail cutting board bracket makes it easy to secure and remove the cutting board and it accepts different sizes too (max. 1/2" thickness)

■ SIDE MOUNT COMPRESSOR UNIT

Through positioning the compressor to the side, the refrigerator can be serviced without being moved. By innovatively creating a front breathing feature, this model can provide high efficiency in narrow spaces.

■ REFRIGERATOR HOLDS 33°F ~ 41°F FOR THE BEST IN FOOD PRESERVATION

* Insulated Pan Cover

Model	Swing Door	CU./FT.	#of Pans	#of Shelves	HP	AMPS	Crated Weight	L D H
TPR-44SD	1	14	6	2	1/3	32	310	44 x 32 1/5 x 36
TPR-67SD	2	20	9	4	2/3	104	550	67 x 32 1/5 x 36
TPR-93SD	3	31	12	6	2/3	110	700	93 1/2 x 32 1/5 x 36

* Height does not include 6" for caster height.

TPR-44SD / TPR-67SD / TPR-93SD SPECIFICATIONS

MODEL	TPR-44SD	TPR-67SD	TPR-93SD
Exterior Dimension (LxDxH)	44x32 ¹ / ₅ x36	67x32 ¹ / ₅ x36	93 ¹ / ₂ x32 ¹ / ₅ x36
Cubic Feet	14	20	31
Compressor (HP)	1/3	2/3	2/3
Shelves	2 ea	4 ea	6 ea
Net Weight	256lbs	395lbs	590lbs
Voltage (i) NEMA-5-15P	(i) 115V / 60Hz	(i) 115V / 60Hz	(i) 115V / 60Hz
Amp	3.2 A	10.4 A	11A
Cord Length	10 ft.	10 ft.	10 ft.
Plug-In	NEMA 5-15P	NEMA 5-15P	NEMA 5-15P

- **SELF-CONTAINED SYSTEM**
- **5" SWIVEL CASTERS**
- **SOLID AND STURDY GRILLE DESIGN**
- **LEGS AVAILABLE FOR ALL MODELS (OPTION)**
- **STANDARD 1/3 SIZE, 6" DEEP CONDIMENT PANS INCLUDED**
- **REMOTE CABINETS AND CONDENSING UNITS AVAILABLE FOR ALL MODELS.**

*Design and specifications subject to change without notice.

▪ **WARRANTY : 2 Years Labor and Parts Warranty
Additional 3 Years Warranty on Compressor**



LISTED COMMERCIAL REFRIGERATOR AND/OR FREEZER 43BK



(unit : inch)

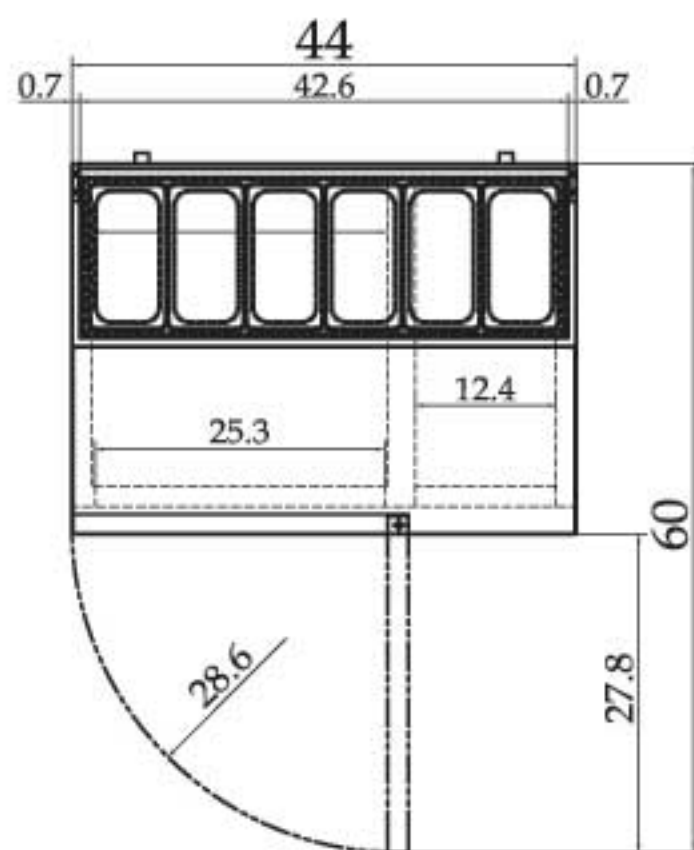

TPR-44SD PLAN VIEW

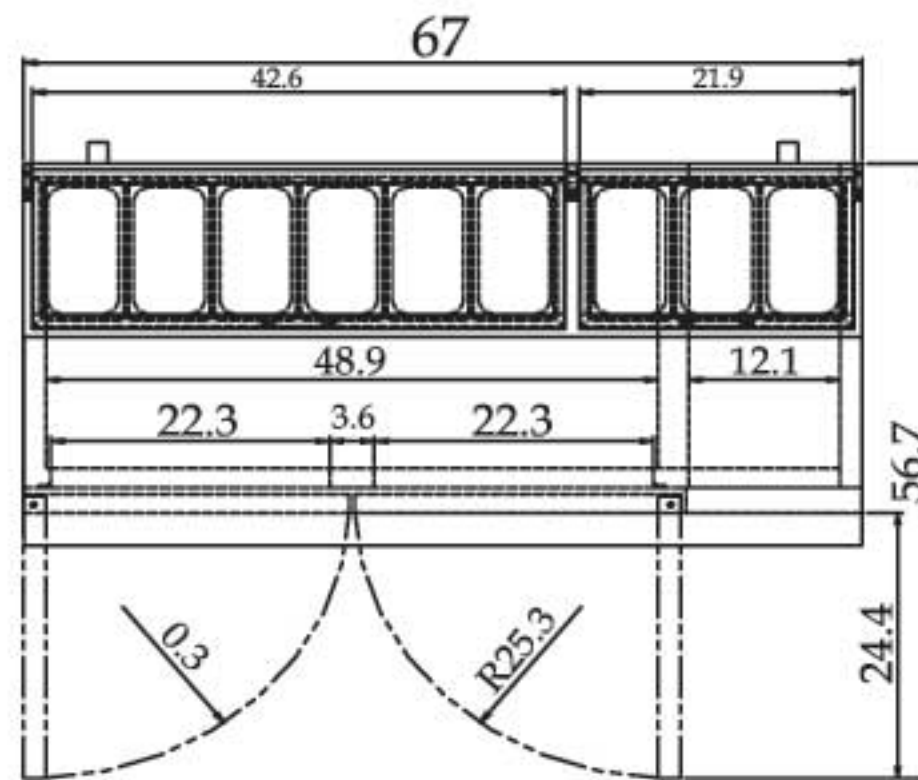

TPR-67SD PLAN VIEW

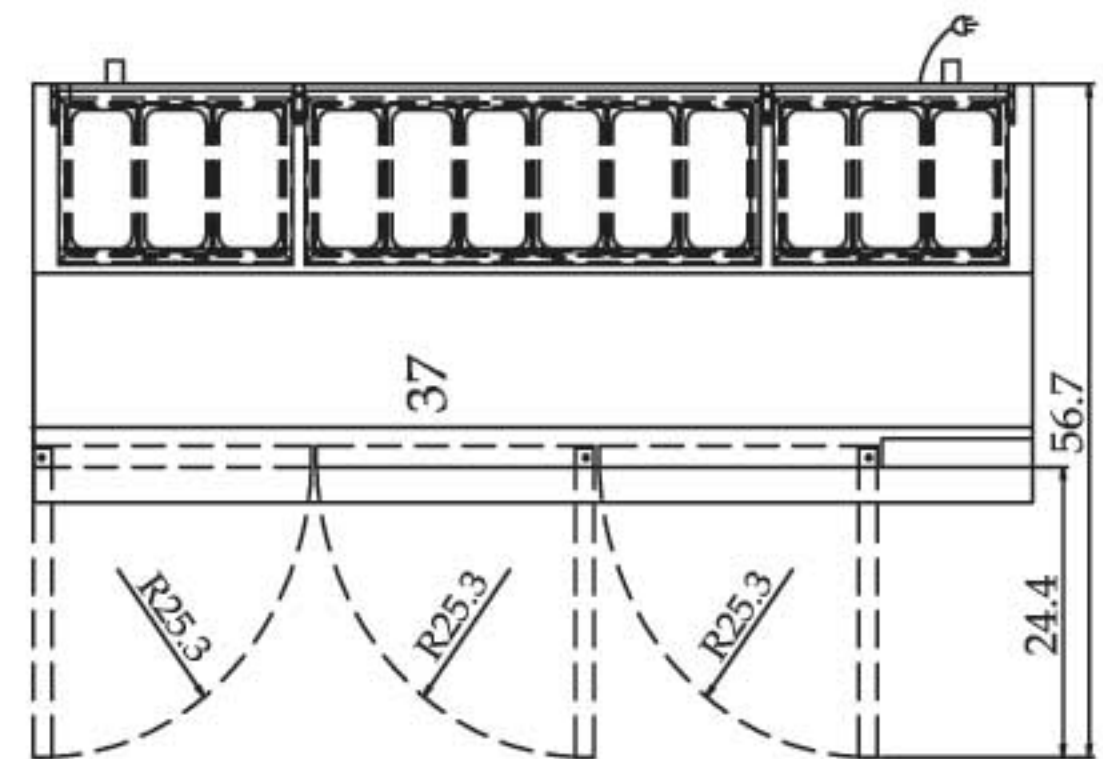

TPR-93SD PLAN VIEW

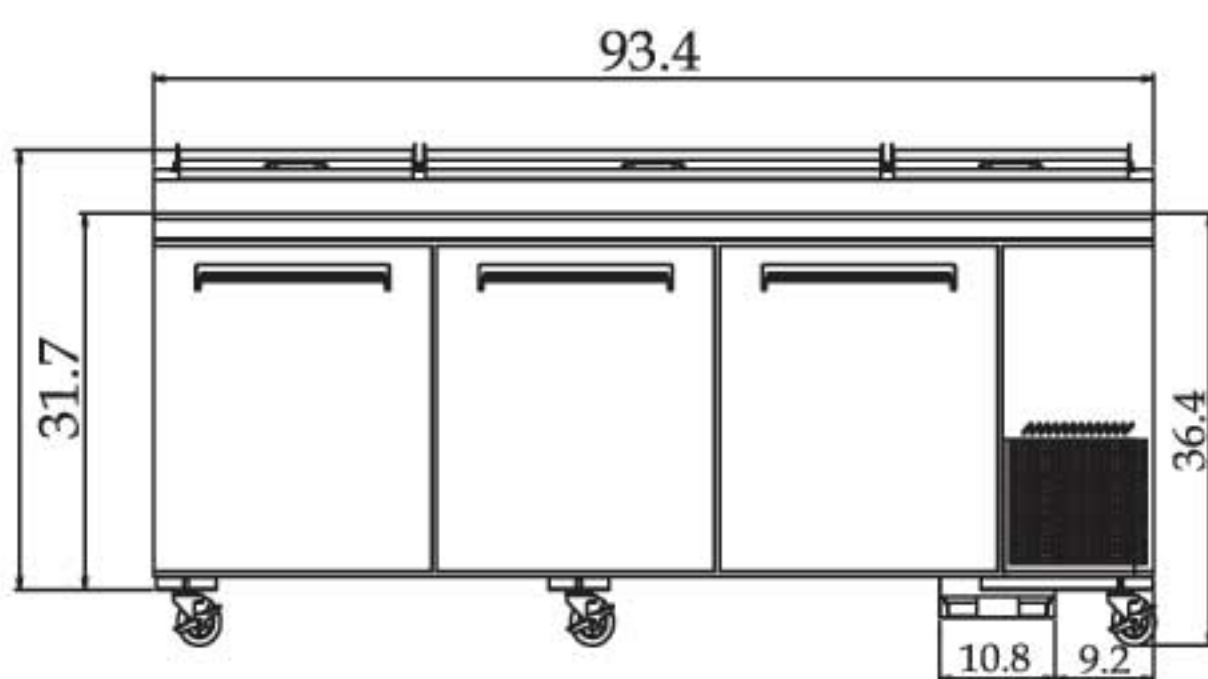

TPR-93SD FRONT VIEW

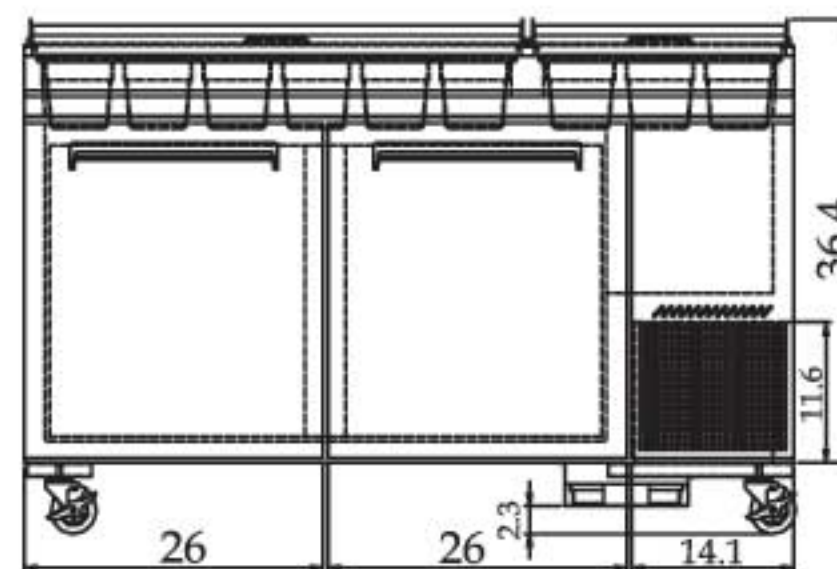

TPR-67SD FRONT VIEW

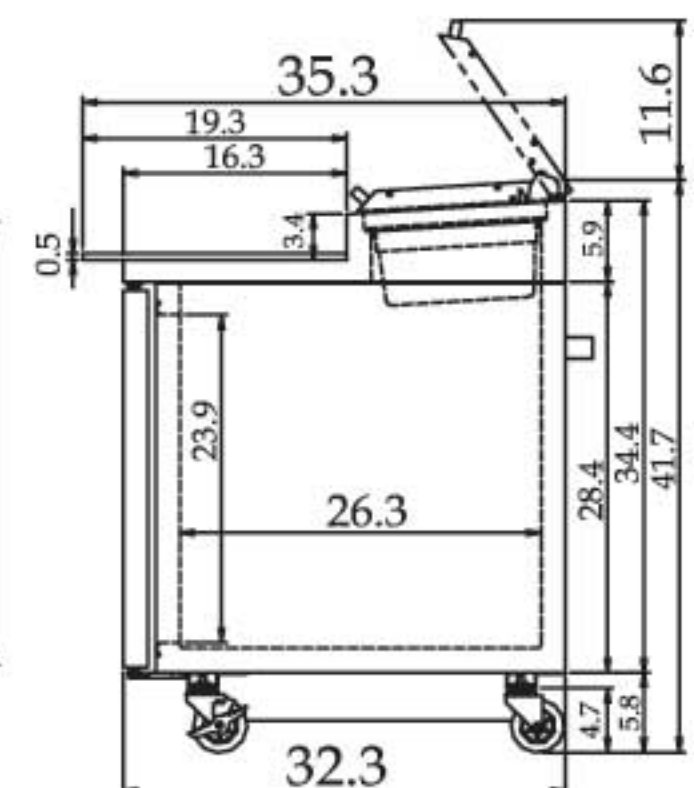

SIDE VIEW