



4184 E. Conant St.  
Long Beach, CA 90808  
Tel. 888-900-1002  
Fax. 310-900-1088  
[www.turboairinc.net](http://www.turboairinc.net)

Project :

Model # :

Item # :

Qty :

Approval :

## Top Mount Package Units (SMART 7)

**Model : STX130MR404A3**

**SMART 7**



### ≡ FEATURES / BENEFITS ≡

**SM 1: Blue Anti-corrosion-fin and Coated Copper Tube**

Protects aluminum and copper pipes from toxic gases generated from foods, retards refrigerant leakage, and prolongs the cooling capacity.

**SM 2: Expansion Valve**

Allows safe storage of foods with a feature that self-adjusts the circulation of refrigerant as the internal temperature changes, thus recovering the required temperature fast.

**SM 3: Compressor Protected Solenoid Valve**

Decreases the inflow of refrigerant into the compressor when it is restarted after a stop. This extends compressor life and reduces compressor failure.

**SM 4: 18% Bigger Condenser than the Standard**

The condenser's efficiency affects most of the refrigerator's performance. Particularly, when used in a small compartment under high ambient temperatures or a dusty area, the package unit's condenser needs to be bigger than standard ones in order to get the best performance. In consideration of the environments that our products may be subject to, condensers utilized in our products are 18% larger than competitors'.

**SM 5: Energy Efficient EC Motor**

Through the use of a highly efficient EC motors, our products reduce energy consumption and lower electricity costs, thus protecting the environment. Our products are designed with easy to replace motor and fan blades.

**SM 6: Highly Efficient Air Circulation Enclosure**

Designed to release hot air to the outside faster than competitors' and to enhance the cooling efficiency. At the same time, it retards elevation of compressor temperature and keeps refrigerant pressure from increasing, thus saving energy as a result.

# Top Mount Package Units (SMART 7)

## Model : STX130MR404A3

### MODEL NOMENCLATURE

| S                                      | T | I                       | 050           | M   | R404A       | 2   |
|--|---|-------------------------|---------------|---|-------------|---|
| Model                                  |   | Location                | Capacity      | Temp.                                     | Refrigerant | Voltage   |
| Turbo air<br>Top Mount<br>Package Unit |   | I= Indoor<br>X= Outdoor | BTUH<br>x 100 | M= Medium<br>Temp.<br><br>L= Low<br>Temp. | R404A       | 1= 115V<br>1PH 60Hz<br><br>2= 208-230V<br>1PH 60Hz<br><br>3= 208-230V<br>3PH 60Hz |

### Performance Data - Medium Temperature Models, Air Defrost

| Model         | Capacity BTU / HR (Ambient Temp) |       |       |       |       |       |       |       |       |       |
|---------------|----------------------------------|-------|-------|-------|-------|-------|-------|-------|-------|-------|
|               | 80°F                             |       | 90°F  |       | 95°F  |       | 100°F |       | 110°F |       |
|               | Room Temperature °F              |       |       |       |       |       |       |       |       |       |
|               | 35°F                             | 38°F  | 35°F  | 38°F  | 35°F  | 38°F  | 35°F  | 38°F  | 35°F  | 38°F  |
| STX130MR404A3 | 16508                            | 17864 | 16036 | 17368 | 15092 | 16376 | 14148 | 15384 | 13676 | 14888 |

### Unit Specifications - Medium Temperature Models

| Model         | Power Supply |    |    | MCA | MOPD | Unit Amps | Evaporator CFM | Plug Supplied | Matching NEMA Receptacle | Dim. Fig. | Net Weight lbs. (kg) | Sound dBA | AWEF Values |
|---------------|--------------|----|----|-----|------|-----------|----------------|---------------|--------------------------|-----------|----------------------|-----------|-------------|
|               | Voltage      | PH | Hz |     |      |           |                |               |                          |           |                      |           |             |
| STX130MR404A3 | 208-230      | 3  | 60 | 9.9 | 15   | 8.3       | 840            | No            | -                        | C         | 325 (148)            | 73        | 5.73        |

Design and specifications subject to change without notice

■ **WARRANTY : 2 Year Compressor and Parts Warranty & 1 Year Labor Warranty**

## PLAN VIEW Opening Size: 25" x 38.5"

(unit : inch)

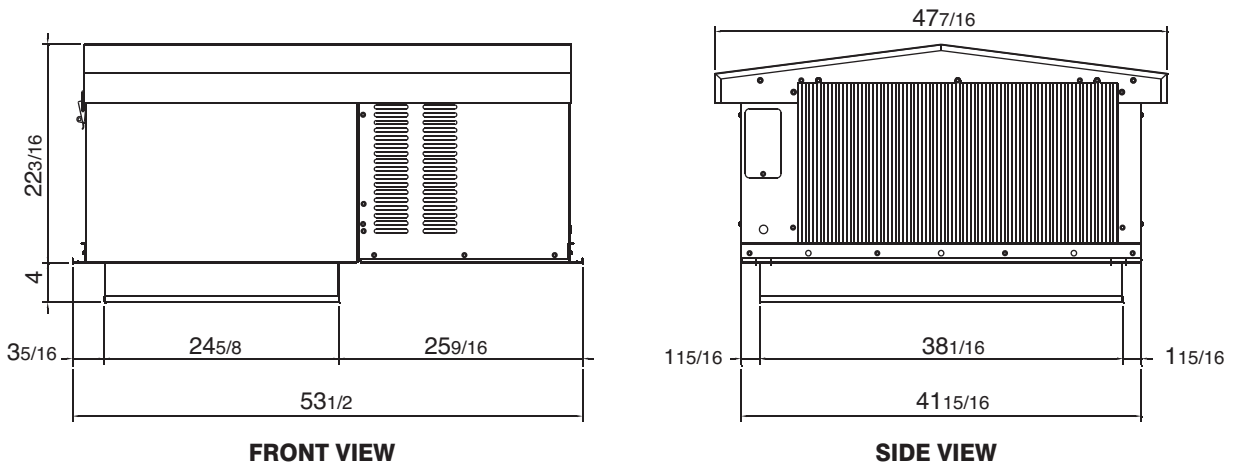

Ver.20180611



■ Toll Free : 888-900-1002

Turbo air REFRIGERATOR MANUFACTURER

GERMAN KNIFE

RADIANCE

Turbo air REFRIGERATOR SYSTEM

TEXAKING