

Project :

Model # :

Item # :

Qty :

Approval :

## Condensing Unit

**Model : TH010MR404A2-T**



### ≡ FEATURES / BENEFITS ≡

- Blue anti-corrosion-fin increases the life span of the coil.
- Seamless inner groove copper tube increases the heat exchange rate by reducing the space between the fin and copper tube.
- Reliable high quality Danfoss compressor.
- Head pressure control stabilizes the freezing of liquid line, minimizes formation of flash gas to increase efficiency of the system, and prevents compressor damage by controlling high pressure.
- Experienced engineers have designed the system for maximum efficiency.
- Fan Blades : Specifically matched with motors and coil for maximum air movement and cooling.
- Control box is designed for easy installation.
- Low pressure control is adjustable.
- All the parts are compliant with industry standards and interchangeable with readily available parts.
- Wiring : Easily accessible. Compressor comes with a wiring harness that is manufactured with connections that will not come loose with vibration.
- Control box and service valves are located outside for easy service.
- Base : Heavy duty steel. Legs are 2-1/6" tall
- Cabinet : Prepainted with galvanized body. Protects against corrosion.
- All products carry UL, cUL, ISO 9001 approvals.

*Danfoss*

# Condensing Unit

## Model : TH010MR404A2-T

### PERFORMANCE CHART

R404A	40°F( SST)	30°F	25°F	20°F	15°F	10°F	0°F	-10°F
90°F(AMBIENT)	-	11972	11167	10185	9410	8471	6877	5258
95°F	-	11422	10390	9699	8730	8051	6345	4825
100°F	-	10871	9873	8970	8277	7420	5991	4536
110°F	-	-	9096	8241	7371	6581	5282	3960

### SPECIFICATION

	TH010MR404A2-T
Compressor	MS26TG
Line Size	3/8" Liquid 5/8" Suction
Refrigerant (Receiver 90%)	6 lbs
Fan Data	1 Fan (980CFM)
Dimensions	24.49(D) x 28.27(W) x 17.87(H)
Net Weight	136 lbs
Power Supply	208-230/1ph/60hz
Compressor Amp	8.3 (RLA), 43(LRA)
MCA/MOPD	15/15

Design and specifications subject to change without notice

- **WARRANTY :** 1 Year Compressor Warranty (4 Year extended warranty available)  
 1 Year Fan Motor and Parts Warranty

### PLAN VIEW

(unit : inch)

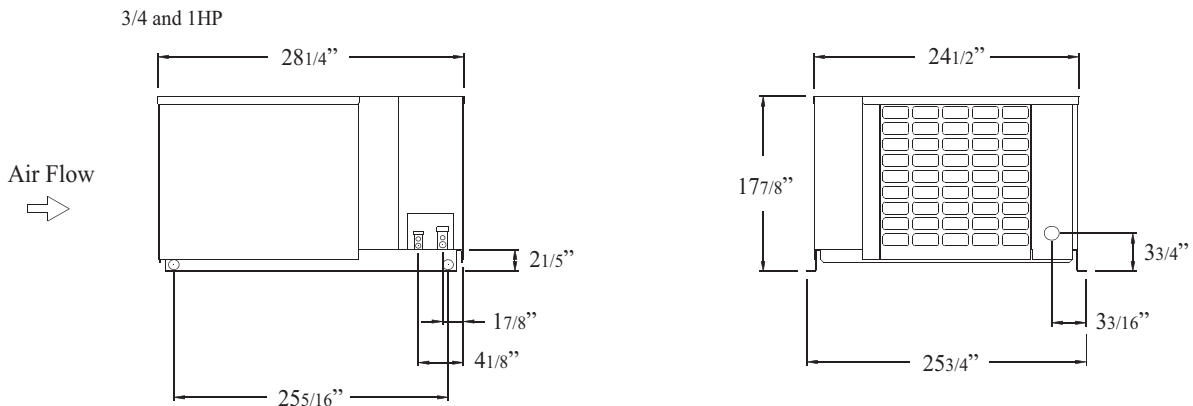

Ver.20180606



■ Toll Free : 888-900-1002