

Condensing Unit

Model : TH015XR404A3



≡ FEATURES / BENEFITS ≡

- Blue anti-corrosion-fin increases the life span of the coil.
- Seamless inner groove copper tube increases the heat exchange rate by reducing the space between the fin and copper tube.
- Highest quality compressor in the world.
- Copeland
- Head pressure control stabilizes the freezing of liquid line, minimizes formation of flash gas to increase efficiency of the system, and prevents compressor damage by controlling high pressure.
- Experienced engineers have designed the system for maximum efficiency.
- Fan Blades : Specifically matched with motors and coil for maximum air movement and cooling.
- Control box is designed for easy installation.
- Low pressure control is adjustable.
- All the parts are compliant with industry standards and interchangeable with readily available parts.
- Wiring : Easily accessible. Compressor comes with a wiring harness that is manufactured with connections that will not come loose with vibration.
- Control box and service valves are located outside for easy service.
- Base : Heavy duty steel. Legs are 2-1/6" tall
- Cabinet : Prepainted with galvanized body. Protects against corrosion.
- All products carry UL, cUL, ISO 9001 approvals.

Condensing Unit

Model : TH015XR404A3

PERFORMANCE CHART

R404A

	0°F(SST)	-5°F	-10°F	-15°F	-20°F	-25°F	-30°F	-40°F
90°F(AMBIENT)	10664	9460	8300	7174	6098	5008	4101	-
95°F	9992	9013	7896	6811	5666	4726	3706	-
100°F	9320	8268	7226	6218	5248	4265	3469	-
110°F	7976	7070	6162	5171	4346	3585	2846	-

SPECIFICATION

Compressor	CF06K6E-TF5
Line Size	3/8" Liquid 5/8" Suction
Refrigerant (Receiver 90%)	6 lbs
Fan Data	1Fan(950CFM)
Dimensions	24.49(D) x 28.27(W) x 17.87(H)
Net Weight	170 lbs
Power Supply	208-230/3ph/60hz
Compressor Amp	7(RLA), 52(LRA)
MCA/MOPD	15/15
Sound dBA	71

Design and specifications subject to change without notice

- **WARRANTY :** 1 Year Compressor Warranty (4 Year extended warranty available)
1 Year Fan Motor and Parts Warranty

PLAN VIEW

(unit : inch)

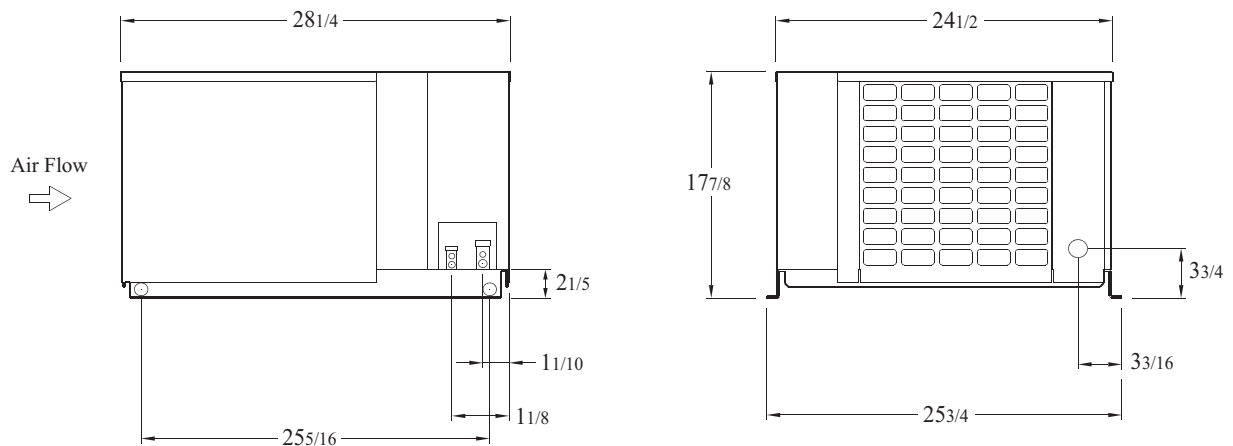

Ver.20180605



■ Toll Free : 888-900-1002

REFRIGERATOR MANUFACTURER
Turbo air

GERMAN
KNIFE

IRADIANCE

REFRIGERATION SYSTEM
Turbo air

Texaking