

Project :

Model # :

Item # :

Qty :

Approval :

## Condensing Unit

**Model : TH025XR404A2**



### ≡ FEATURES / BENEFITS ≡

- Blue anti-corrosion-fin increases the life span of the coil.
- Seamless inner groove copper tube increases the heat exchange rate by reducing the space between the fin and copper tube.
- Highest quality compressor in the world.
- Copeland
- Head pressure control stabilizes the freezing of liquid line, minimizes formation of flash gas to increase efficiency of the system, and prevents compressor damage by controlling high pressure.
- Experienced engineers have designed the system for maximum efficiency.
- Fan Blades : Specifically matched with motors and coil for maximum air movement and cooling.
- Control box is designed for easy installation.
- Low pressure control is adjustable.
- All the parts are compliant with industry standards and interchangeable with readily available parts.
- Wiring : Easily accessible. Compressor comes with a wiring harness that is manufactured with connections that will not come loose with vibration.
- Control box and service valves are located outside for easy service.
- Base : Heavy duty steel. Legs are 2-1/6" tall
- Cabinet : Prepainted with galvanized body. Protects against corrosion.
- All products carry UL, cUL, ISO 9001 approvals.

# Condensing Unit

## Model : TH025XR404A2

### PERFORMANCE CHART

R404A

	0°F(SST)	-5°F	-10°F	-15°F	-20°F	-25°F	-30°F	-40°F
90°F(AMBIENT)	16820	14750	13030	11070	9460	7804	6318	-
95°F	15660	13910	12080	10245	8584	7174	5884	-
100°F	14700	12860	11320	9587	8146	6554	5369	-
110°F	12580	10979	9616	8120	6880	5611	4484	-

### SPECIFICATION

Compressor	CF09K6E-PFV
Line Size	3/8" Liquid 7/8" Suction
Refrigerant (Receiver 90%)	9 lbs
Fan Data	2Fan(1600CFM)
Dimensions	38.50(D) x 28.27(W) x 17.87(H)
Net Weight	222 lbs
Power Supply	208-230/1ph/60hz
Compressor Amp	16.7(RLA), 87(LRA)
MCA/MOPD	21.8/30
Sound dBA	73

Design and specifications subject to change without notice

- **WARRANTY :** 1 Year Compressor Warranty (4 Year extended warranty available)  
1 Year Fan Motor and Parts Warranty

### PLAN VIEW

(unit : inch)

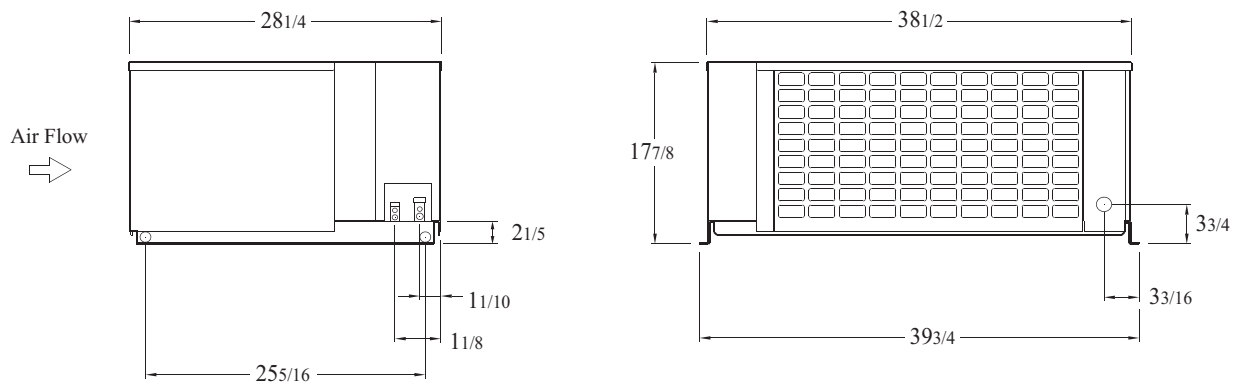

Ver.20180605



■ Toll Free : 888-900-1002

Turbo air REFRIGERATOR MANUFACTURER

GERMAN KNIFE

RADIANCE

Turbo air REFRIGERATION SYSTEM

TEXAKING