

Project :

Model # :

Item # :

Qty :

Approval :

Condensing Unit

Model : TH032LR404A3



≡ FEATURES / BENEFITS ≡

- Blue anti-corrosion-fin increases the life span of the coil.
- Seamless inner groove copper tube increases the heat exchange rate by reducing the space between the fin and copper tube.
- Highest quality compressor in the world.
- Copeland
- Head pressure control stabilizes the freezing of liquid line, minimizes formation of flash gas to increase efficiency of the system, and prevents compressor damage by controlling high pressure.
- Experienced engineers have designed the system for maximum efficiency.
- Fan Blades : Specifically matched with motors and coil for maximum air movement and cooling.
- Control box is designed for easy installation.
- Low pressure control is adjustable.
- All the parts are compliant with industry standards and interchangeable with readily available parts.
- Wiring : Easily accessible. Compressor comes with a wiring harness that is manufactured with connections that will not come loose with vibration.
- Control box and service valves are located outside for easy service.
- Base : Heavy duty steel. Legs are 2-1/6" tall
- Cabinet : Prepainted with galvanized body. Protects against corrosion.
- All products carry UL, cUL, ISO 9001 approvals.

Condensing Unit

Model : TH032LR404A3

PERFORMANCE CHART

R404A

	40°F(SST)	30°F	25°F	20°F	0°F	-10°F	-20°F	-25°F
90°F(AMBIENT)	-	34200	31310	28580	16910	11960	9440	6930
95°F	-	32260	29540	26960	15950	11280	8910	6540
100°F	-	30320	27770	25340	14990	10600	8380	6150
110°F	-	26350	24040	21690	12250	8020	6340	4650

SPECIFICATION

	TH032LR404A3
Compressor	CS20K6E-TF5
Line Size	1/2" Liquid 7/8" Suction
Refrigerant (Receiver 90%)	18 lbs
Fan Data	1 Fan (3970CFM)
Dimensions	30.28(D) x 38.5(W) x 27.28(H)
Net Weight	274 lbs
Power Supply	208-230/3ph/60hz
Compressor Amp	11.4(RLA), 75f(LRA)
MCA/MOPD	16.5/20
Sound dBA	73

Design and specifications subject to change without notice

- **WARRANTY :** 1 Year Compressor Warranty (4 Year extended warranty available)
1 Year Fan Motor and Parts Warranty

(unit : inch)

PLAN VIEW

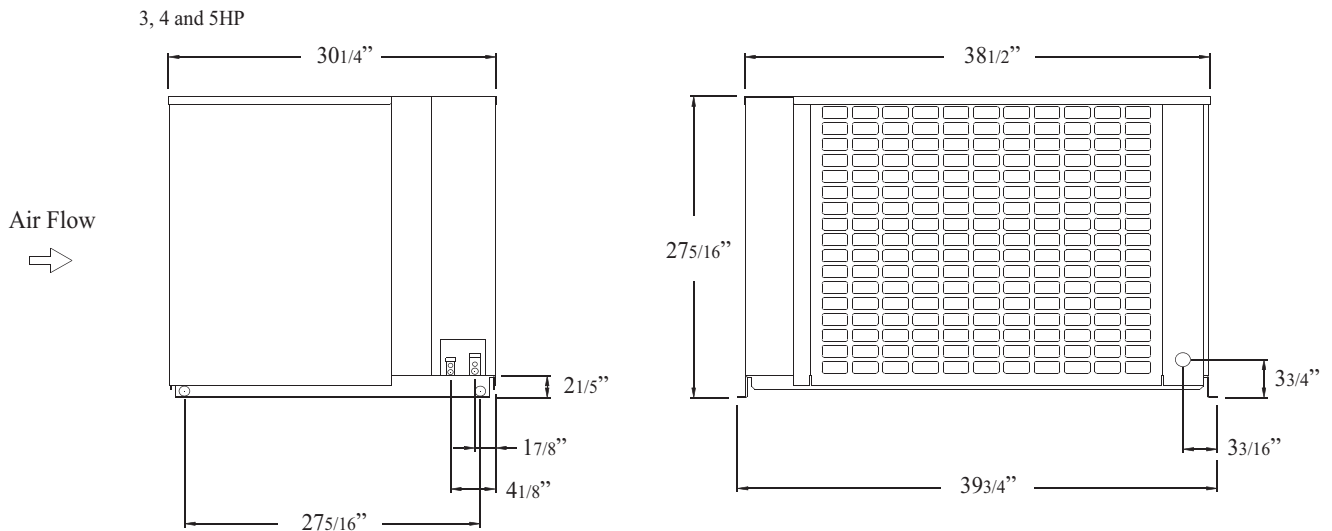

Ver.20180606



▪ Toll Free : 888-900-1002

Turbo air REFRIGERATOR MANUFACTURER

GERMAN KNIFE

RADIANCE

Turbo air REFRIGERATION SYSTEM

TEXAKING