



4184 E. Conant st.
 Long Beach, CA 90808
 Tel. 800-500-3519
 Fax. 310-900-1066
www.turboairinc.com

Project :	
Model # :	
Item # :	Qty :
Available W/H :	
Approval :	

Heavy Duty Slicer - Manual *Heavy Duty Premium Slicers*

Model : GS-12M



≡ FEATURES & BENEFITS ≡

- **1/2 HP knife motor**
 Powerful 1/2 HP knife motor assures peak performance when slicing the toughest products.
- **Powerful gear driven knife motor**
 German Knife's heavy-duty gear drive system provides years of maintenance free reliability without down time. No belts to slip or break.
- **Half-permanently lubricated worm gears**
 Worm gears are made of Nytratron that is self-lubricated plastic made in Germany for high-speed equipment.
- **Stainless steel receiving plate**
- **Stainless steel for food zone**
 Stainless steel food contact zone provides easy to clean surfaces and won't chip or peel.
- **Oil lubrication system on top and bottom slide shaft**
 Oil lubrication system on top and bottom slide shaft provides smooth sliding for the chute compared with competing brands.
- **Top mount knife sharpener**
- **Ergonomic style chute handle**
 Comfortable and stable ergonomic style grip on the chute handle provides easy glide manual operation.
- **Knife blade**
 Knife made in Germany holds the cutting edge longer requires less sharpenings, corrosion resistant and provides precise cuts.
- **Heavy stainless steel end weight**
 Heavy end weight lets you slice tiny pieces to the end and eliminates waste.
- **Operator side end weight rod**
 By placing the weight rod on the operator side of the chute, the product is held tighter for slicing.
- **Safe knife cleaning**
 German Knife heavy duty slicers are equipped with a permanently attached knife ring guard and interlock knife cover.
- **Slice thickness adjustment**
 Precise thickness adjustment lets you slice from tissue thin to 1" thick.

Model	Knife Motor HP	Chute Motor HP	Crated Weight (lbs.)	L x D x H (inches)
GS-12M	1/2	-	153	25⁵/₈ x 23³/₈ x 23⁵/₈

Model : GS-12M

ELECTRICAL DATA	
Knife Motor	1/2HP • 1ph • AC115V • 60Hz
Chute Motor	-
Speed	-
DIMENSIONAL DATA	
Diameter of Knife	12
Slices Thickness	Tissue thin ~ 1" thick
Foot Print (in.)	17 ³ / ₄ x 22 ³ / ₈
Ext. Length Overall (in.)	25 ⁵ / ₈ (650mm)
Ext. Depth Overall (in.)	23 ³ / ₈ (594mm)
Ext. Height Overall (in.)	23 ⁵ / ₈ (599mm)
Net Weight (lbs.)	130
Gross Weight (lbs.)	153
Box Dimensions (L x D x H) (in.)	29 ¹ / ₂ x 28 ¹ / ₄ x 27 ¹ / ₂

Design and specifications subject to change without notice.
Actual shipping weight may differ due to extra packing materials for product protection.

- **WARRANTY : 2 Year Parts and Labor Warranty**
- **Vegetable Hopper Available**

PLAN VIEW

(unit : inch)

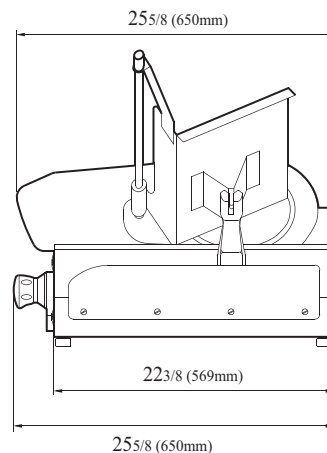

FRONT VIEW

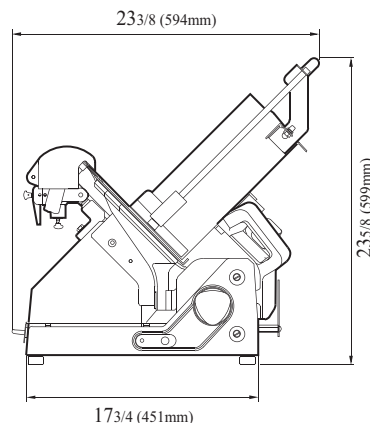

SIDE VIEW

Ver.20210430



- Turbo Air : 800-627-0032
- GK : 800-500-3519
- Warranty : 800-381-7770
- AC : 888-900-1002