



4184 E. Conant St.
Long Beach, CA 90808
Tel. 888-900-1002
Fax. 310-900-1088
www.turboairinc.net

Project :

Model # :

Item # :

Qty :

Approval :

Top Mount Package Units (SMART 7)

Model : ST1070LR448A2

SMART 7



FEATURES / BENEFITS

SM 1: Blue Anti-corrosion-fin and Coated Copper Tube

Protects aluminum and copper pipes from toxic gases generated from foods, retards refrigerant leakage, and prolongs the cooling capacity.

SM 2: Expansion Valve

Allows safe storage of foods with a feature that self-adjusts the circulation of refrigerant as the internal temperature changes, thus recovering the required temperature quickly.

SM 3: Compressor Protected Solenoid Valve

Decreases the inflow of refrigerant into the compressor when it is restarted after a stop. This extends compressor life and reduces compressor failure.

SM 4: 18% Bigger Condenser than the Standard

The condenser's efficiency affects most of the refrigerator's performance. Particularly, when used in a small compartment under high ambient temperatures or a dusty area, the package unit's condenser needs to be bigger than standard ones in order to achieve the best performance. In consideration of the environments that our products may be subject to, condensers utilized in our products are 18% larger than competitors'.

SM 5: Energy Efficient EC Motor

Through the use of highly efficient EC motors, our products reduce energy consumption and lower electricity costs, thus protecting the environment. Our products are designed with easy-to-replace motor and fan blades.

SM 6: Leak Free Patented Hot Gas Condensate System

The hot gas condensate system is an ideal system because of its fast evaporation of condensed water and its enhancing refrigeration efficiency. In spite of these advantages, many companies have stopped the application of such a system because of the high risk of discarding the refrigerators due to the rapid corrosion of hot gas lines causing refrigerant leakage and water inflow into the cooling pipes. Such problems are completely resolved in our products, thanks to a patented technology that prevents pipes from corrosion.

SM 7: Highly Efficient Air Circulation Enclosure

This system is designed to release hot air to the outside faster than competitors' and to enhance cooling efficiency. At the same time, it retards elevation of compressor temperature and keeps refrigerant pressure from increasing, thus saving energy as a result.

Top Mount Package Units (SMART 7)

Model : STI070LR448A2

Performance Data - Low Temperature Model, Electric Defrost

Model	Capacity BTU / HR (Ambient Temp)														
	80°F			90°F			95°F			100°F			110°F		
	Room Temperature °F														
	0°F	-10°F	-20°F	0°F	-10°F	-20°F	0°F	-10°F	-20°F	0°F	-10°F	-20°F	0°F	-10°F	-20°F
STI070LR448A2	9320	7350	5731	8780	6945	5438	8414	6718	5275	8107	6488	5070	7535	6069	4761

Unit Specifications - Low Temperature Model

Model	Power Supply					Unit Amps	Evaporator CFM	Plug Supplied	Matching NEMA Receptacle	Sound dBA	Net Weight lbs (kg)	AWEF Value
	Voltage	PH	Hz	MCA	MOPD							
STI070LR448A2	208-230	1	60	22.6	35	18.6	1647	† NO	-	76	288 (131)	2.48

Design and specifications subject to change without notice.

■ **WARRANTY : 2 Year Compressor and Parts Warranty & 1 Year Labor Warranty**

PLAN VIEW

(unit : inch)

Opening Size : 25" x 38.5"

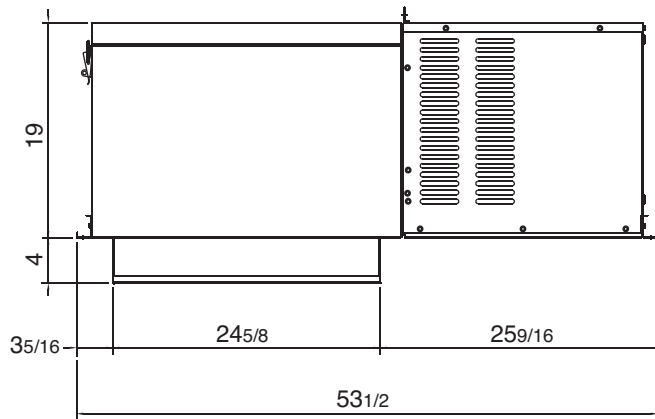

FRONT VIEW

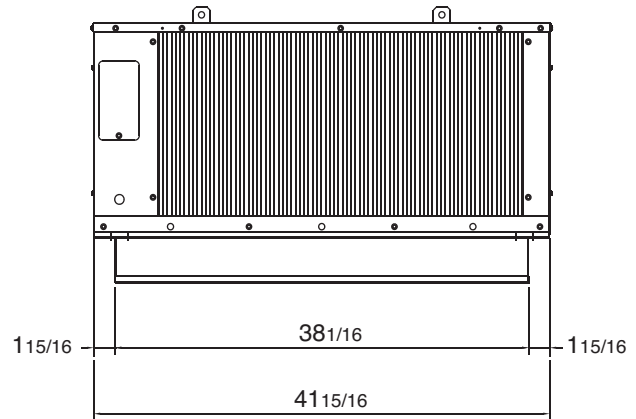

SIDE VIEW

Ver.20210518



■ Toll Free : 888-900-1002

Turbo air REFRIGERATOR MANUFACTURER

GERMAN KNIFE

RADIANCE

Turbo air REFRIGERATION SYSTEM

TEXAKING