

Project :

Model # :

Item # :

Qty :

Approval :

## Condensing Unit

**Model : TS025XR404A3A**



### ≡ FEATURES / BENEFITS ≡

- Blue anti-corrosion-fin increases the life span of the coil.
- Seamless inner groove copper tube increases the heat exchange rate by reducing the space between the fin and copper tube.
- Highest quality compressor in the world.
- Control box is designed for easy installation.
- Low pressure control is adjustable.
- All the parts are compliant with industry standards and interchangeable with readily available parts.
- Wiring: Easily accessible. Compressor comes with a wiring harness that is manufactured with connections that will not come loose with vibration.
- Control box and service valves are located outside for easy service.
- Base: Heavy duty steel. Legs are 2-1/6" tall
- Cabinet: Prepainted with galvanized body. Protects against corrosion.
- All products carry UL, cUL, ISO 9001 approvals.



# Condensing Unit

## Model : TS025XR404A3A

### PERFORMANCE CHART

R448/449A

	0°F	-10°F	-15°F	-20°F	-25°F	-30°F	-35°F	-40°F
90°F(AMBIENT)	12880	10690	9670	8702	7773	6850	5930	5016
95°F	12480	10330	9370	8445	7544	6648	5777	4840
100°F	12093	10035	9119	8230	7349	6478	5612	4648
110°F	11327	9519	8657	7822	6950	6149	5272	4347

R404A

	0°F	-10°F	-15°F	-20°F	-25°F	-30°F	-35°F	-40°F
90°F(AMBIENT)	14150	11600	10609	9530	8533	7612	6760	5961
95°F	13500	11100	10063	9056	8120	7314	6445	5682
100°F	12833	10578	9595	8653	7770	6942	6170	5388
110°F	11633	9612	8719	7873	7080	6336	5635	4966

### SPECIFICATION

	<b>TS025XR404A3A</b>
Compressor	ZF08K4E-TF5
Line Size	1/2" Liquid 7/8" Suction
Refrigerant (Receiver 90%)	15 lbs
Fan Data	2 Fan (2936CFM)
Dimensions	38.5(D) x 28.25(W) x 20.75(H)
Net Weight	246 lbs
Power Supply	208-230/3ph/60hz
Compressor Amp	9.6(RLA), 63(LRA)
MCA/MOPD	15.0/20
Sound dBA	68
AWEF Value (R-404A, R-448A / R-449A)	3.2, 3.2

Design and specifications subject to change without notice

- **WARRANTY :** 1 Year Compressor Warranty (4 Year extended warranty available)  
1 Year Fan Motor and Parts Warranty

### PLAN VIEW

(unit : inch)

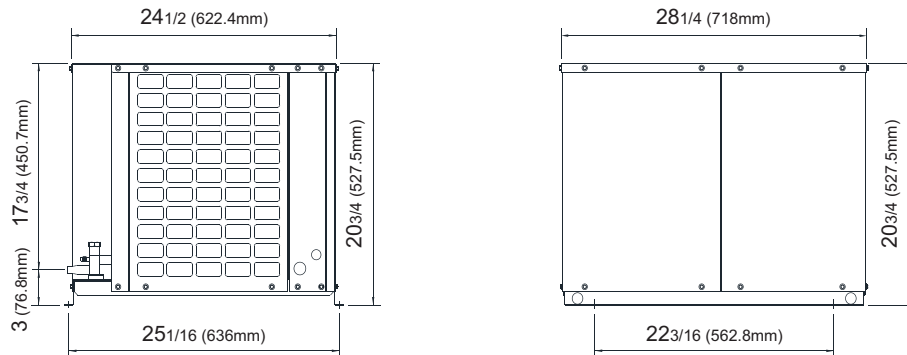

Ver.20201203



■ Toll Free : 888-900-1002

REFRIGERATOR MANUFACTURER  
**Turbo air**

**GERMAN KNIFE**

**RADIANCE**

REFRIGERATION SYSTEM  
**Turbo air**

**TEXAKING**