

**REFRIGERATOR MANUFACTURER**  
**Turbo air**  
 more durable, efficient, beautiful

4184 E. Conant St.  
 Long Beach, CA 90808  
 Tel. 310-900-1000  
 Fax. 310-900-1077  
[www.turboairinc.com](http://www.turboairinc.com)

Project:	
Model #:	
Item #:	
Available W/H:	Qty:
Approval:	
AIA #:	SIS #:
CSI Section 11400	

## Solid Door Freezer

Reach-In Top Mount  
**M3 Series**

**Model : M3F72-3-N**

### FEATURES & BENEFITS

#### Self-Cleaning Condenser

The accumulation of dust in the condenser can cause the failure or breakdown of refrigerators. Refrigerators run normally until they reach a certain level of accumulation. At some point, when they are over the limit, their performance drops quickly resulting in damage to, or disposal of the stored products inside. The Self-Cleaning Condenser device keeps the condenser clean and prevents system failure by automatically brushing daily.

#### Digital temperature control & monitor system

- Keeps food products safe by maintaining constant temperatures
- Alarms that sound when doors are not sealed shut; protect against food spoilage that originates from cold air leaks
- Early warning alarm program detects issues before malfunction occurs
- Digital display allows for easy monitoring
- Programs interpret the condition of refrigeration systems by self-diagnosis
- Rapid cool-down function (Turbo Freeze)
- Smart defrost system will defrost as needed
- Automatic evaporator fan motor delays

#### Hydrocarbon refrigerants (R-290)

With innovative and eco-friendly technology, Turbo Air brings you hydrocarbon refrigerators designed to meet DOE's Energy Conservation Standards in 2017 and to use EPA's SNAP Program approved HC refrigerants. Hydrocarbon refrigerants do not deplete the ozone layer and have very low contribution to global warming (ODP-0, GWP-3).

#### Stainless steel exterior

The Turbo Air M3 freezer model boasts a stainless steel exterior (galvanized steel top, bottom and back) and AL interior with stainless steel floor. It guarantees the utmost in cleanliness and long product life. Sharp corners and edges have been rounded to reduce the risk of injury. The M3 adds a touch of style to the most refined setting.

#### Door pressure release device

Pressure relief doors are designed to eliminate vacuum pressure and allow easy door opening.

#### LED interior lighting

#### Adjustable, heavy duty, PE (polyethylene) coated wire shelves

#### High-density polyurethane insulation

The entire cabinet structure and solid doors are foamed-in-place using high density, CFC free polyurethane insulation.

#### Top mount compressor

#### Freezer holds -10°F ~ 0°F for the best in frozen food preservation



#### Patented Self-Cleaning Condenser

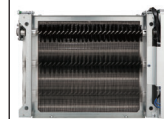

This product is equipped with a fine mesh filter to the front of the condenser to catch dust, and a rotating brush that moves up and down daily to remove excess buildup outward and away.

**NATURAL Refrigerant**

ETL Intertek

ETL Intertek

5 YEAR WARRANTY

Compressor **7 YEAR WARRANTY** (U.S.A. only)

Model	Swing Doors	CU./FT.	#of Shelves	HP	AMPS	Crated Weight (lbs.)	L x D* x H† (inches)
M3F72-3-N	3	65.8	9	3/4	7.9	571	77 <sup>3</sup> / <sub>4</sub> x 30 <sup>3</sup> / <sub>4</sub> x 77 <sup>7</sup> / <sub>8</sub>

## Model : M3F72-3-N

ELECTRICAL DATA	
Voltage	115/60/1
Plug Type	 NEMA 5-15P
Full Load Amperes	7.9
Compressor HP	3/4
Cord Length (ft.)	9
Refrigerant	R-290
DIMENSIONAL DATA	
# of Doors	3
# of Racks Accepted	3
Net Capacity (cu. ft.)	65.8
Ext. Length Overall (in.)	77 <sup>3</sup> / <sub>4</sub> (1975mm)
Ext. Depth Overall (in.)*	30 <sup>3</sup> / <sub>4</sub> (780mm)
Ext. Height Overall (in.)†	77 <sup>7</sup> / <sub>8</sub> (1979mm)
Int. Length Overall (in.)	73 <sup>7</sup> / <sub>8</sub> (1875mm)
Int. Depth Overall (in.)	24 <sup>3</sup> / <sub>4</sub> (630mm)
Int. Height Overall (in.)	54 <sup>1</sup> / <sub>8</sub> (1374mm)
# of Shelves	9
Shelf Size (L x D) (in.)	23 x 23 <sup>1</sup> / <sub>2</sub> (Left/Right)
	25 <sup>1</sup> / <sub>4</sub> x 23 <sup>1</sup> / <sub>2</sub> (Middle)
Net Weight (lbs.)	527
Gross Weight (lbs.)	571

Design and specifications subject to change without notice.  
Actual shipping weight may differ due to extra packing materials for product protection.  
\* Depth does not include 2-1/4" for rear condensate enclosure.  
† Height does not include 4-3/4" for caster height.

### ■ WARRANTY : 5 Year Parts and Labor Warranty 7 Year Compressor Warranty

### ■ STANDARD FEATURES

- Anti-corrosion coated evaporator
- Self-contained system
- 4" dia. swivel casters with locks on the front set
- Door locks
- Magnetic door gaskets
- Solid and sturdy grille design

### ■ OPTIONAL ACCESSORIES

- 2.5" caster, 1/2" diameter & 13 TPI: 30265H0100 (non-brake), 30265H0200 (w/ brake)
- 5" caster, 1/2" diameter & 13 TPI: M726500100 (non-brake), M726500200 (w/ brake)
- 6" stainless steel leg: 30221M0600
- Additional PE coated wire shelf: G8F1800101 (Left/Right), G8F1800201 (Middle)
- Half door bun tray rack: TSP-2224 (each holds up to six 18"L x 26"D sheet pans)
- Full door bun tray rack: TSP-2250 (each holds up to fifteen 18"L x 26"D sheet pans)

Ver.20260129

## PLAN VIEW

(unit : inch)

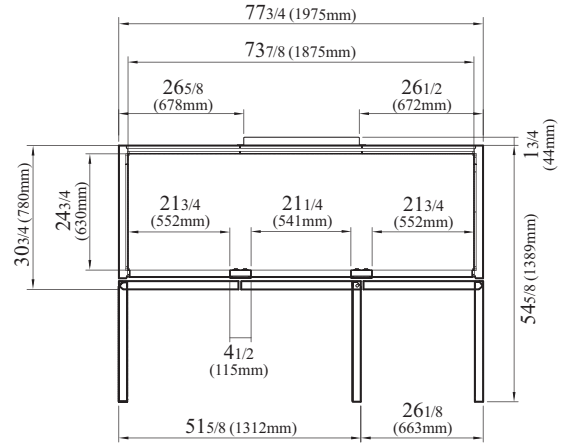

TOP VIEW

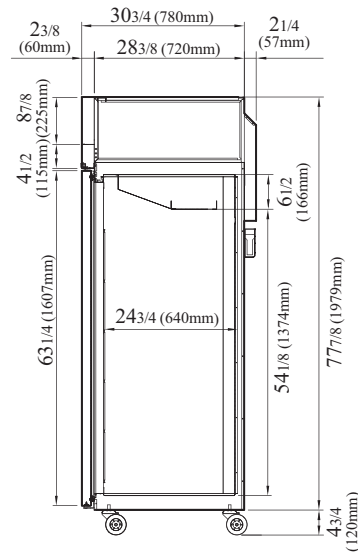

SIDE VIEW



- Turbo Air: 800-627-0032
- Bake Tech Innovation: 800-500-3519
- Warranty: 800-381-7770
- AC: 888-900-1002



Continued product development may necessitate specification changes without notice.