

REFRIGERATOR MANUFACTURER
Turbo air
 more durable, efficient, beautiful

4184 E. Conant St.
 Long Beach, CA 90808
 Tel. 310-900-1000
 Fax. 310-900-1077
www.turboairinc.com

Project:	
Model #:	
Item #:	
Available W/H:	Qty:
Approval:	
AIA #:	SIS #:
CSI Section 11400	

Mega Top Unit - Slide Back Lid

Food Prep Tables
 Super Deluxe Series

Patented Self-Cleaning Condenser

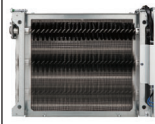

This product is equipped with a fine mesh filter to the front of the condenser to catch dust, and a rotating brush that moves up and down daily to remove excess buildup outward and away.



Removable cover with slide back lid

Model : TST-48SD-18-D4-N-SL



≡ FEATURES & BENEFITS ≡

■ Self-Cleaning Condenser

The accumulation of dust in the condenser can cause the failure or breakdown of refrigerators. Refrigerators run normally until they reach a certain level of accumulation. At some point, when they are over the limit, their performance drops quickly resulting in damage to, or disposal of the stored products inside. The Self-Cleaning Condenser device keeps the condenser clean and prevents system failure by automatically brushing daily.

■ Digital temperature control & monitor system

Keeps food products safe by maintaining constant temperatures. External digital display allows for easy monitoring.

■ Hydrocarbon refrigerants (R-290)

With innovative and eco-friendly technology, Turbo Air brings you hydrocarbon refrigerators designed to meet DOE's Energy Conservation Standards in 2017 and to use EPA's SNAP Program approved HC refrigerants. Hydrocarbon refrigerants do not deplete the ozone layer and have very low contribution to global warming (ODP-0, GWP-3).

■ Cold Bunker system

Our innovative forced air system allows cold air to flow all around the food pan area, covering not only underneath the pan, but also the front, top and the rear. This unique air flow creates a cold air-shield around the pan, which maintains the food temperature at under 41°F (NSF requirement) even when the lids are opened. In addition, the compartment isolates pans from the reach-in area to prevent food spillage.

■ LED interior lighting & fan control

Energy efficient LED lighting lights every corner, making items easy to find. Fan control function automatically shuts off the fan when the door is open, which prevents hot air from being drawn in, thus maintaining the cool inner temperature.

■ Stainless steel cabinet construction

The Turbo Air Super Deluxe model boasts all stainless steel exterior including back (galvanized bottom) and stainless steel interior with ABS door liner. It guarantees the utmost in cleanliness and long product life. The Super Deluxe adds a touch of style to the most refined setting.

■ Sturdy, clean stainless steel shelving

Shelves are the most important part of cleanliness as they come in direct contact with food. After a while, PVC coated wire shelves may peel, rust and lead to unsanitary conditions. Only the Turbo Air Super Deluxe series uniquely provides stainless steel shelving.

■ Removable insulated slide-back lid

Removable hood and slide-back lid are easy to clean while providing a better view of the top opening.

■ 9-1/2" deep, 1/2" thick high-density Polyethylene cutting board included with convenient side rail

■ High-density polyurethane insulation

The entire cabinet structure and solid doors are foamed-in-place high density, CFC free polyurethane insulation.

■ Refrigerator holds 33°F ~ 39°F for the best in food preservation



Model	Drawers	CU./FT.	#of Shelves	#of Pans	HP	AMPS	Crated Weight (lbs.)	L x D x H [†] (inches)
TST-48SD-18-D4-N-SL	4	15	-	18	1/3	4.4	286	483/8 x 37 x 441/2

Mega Top Unit - Slide Back Lid

Food Prep Tables
Super Deluxe Series

Model : TST-48SD-18-D4-N-SL

ELECTRICAL DATA	
Voltage	115/60/1
Plug Type	 NEMA 5-15P
Full Load Amperes	4.4
Compressor HP	1/3
Cord Length (ft.)	9
Refrigerant	R-290
DIMENSIONAL DATA	
Ext. Length Overall (in.)	48 ³ / ₈ (1227mm)
Ext. Depth Overall (in.)*	37 (939mm)
Ext. Height Overall (in.)†	44 ¹ / ₂ (1130mm)
# of Drawers	4
# of Shelves	-
# of Pans	18
# of Hood	1
Net Capacity (cu. ft.)	15
Net Weight (lbs.)	264
Gross Weight (lbs.)	286

Design and specifications subject to change without notice.
Actual shipping weight may differ due to extra packing materials for product protection.
* Depth does not include 3" for cutting board and 1" for rear spacers.
† Height does not include 4-1/2" for caster height.

■ **WARRANTY :** 5 Year Parts and Labor Warranty
7 Year Compressor Warranty

■ STANDARD FEATURES

- Anti-corrosion coated evaporator
- Self-contained system
- 4" dia. swivel casters with locks on the front set
- 1/6 size, 4" deep condiment pans included

* Accommodates 1/6 size, 6" deep condiment pans

** Lead time applies. Please contact your sales representative for more details to order.

■ OPTIONAL ACCESSORIES

- 1" caster, 1/2" diameter & 13 TPI: S28R813660 (non-brake)
- 2.5" caster, 1/2" diameter & 13 TPI: 30265H0100 (non-brake), 30265H0200 (w/ brake)
- 5" caster, 1/2" diameter & 13 TPI: M726500100 (non-brake), M726500200 (w/ brake)
- Leveling leg, 1/2" - 13 TPI x 1.54": LFM1213566
- 6" ABS plastic leg: 30221M0200
- 6" stainless steel leg: 30221M0600
- Additional stainless steel shelf: M727800100
- Single overshelf, stainless steel, 48-3/8" W: TSOS-4S
- Double overshelf, stainless steel, 48-3/8" W: TSOS-4R-T
- **Door lock: lead time applies. Please contact your sales representative for more details to order.**

PLAN VIEW

(unit : inch)

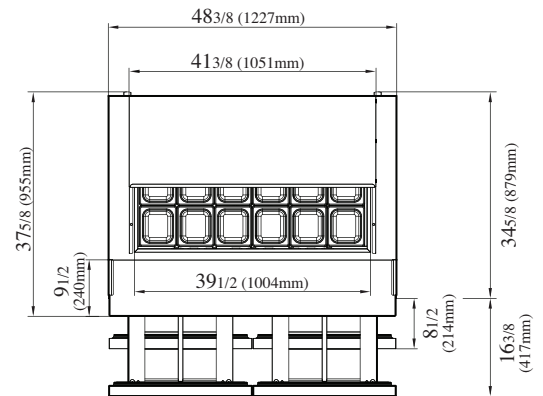

TOP VIEW

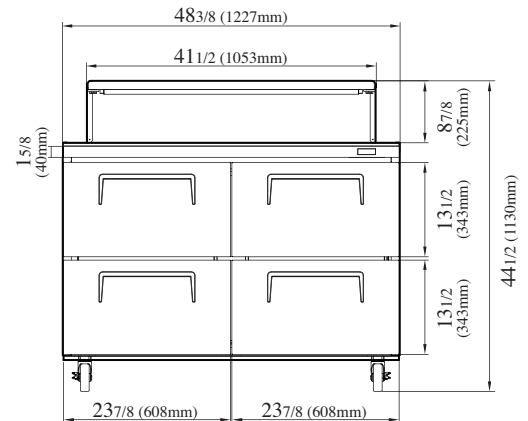

FRONT VIEW

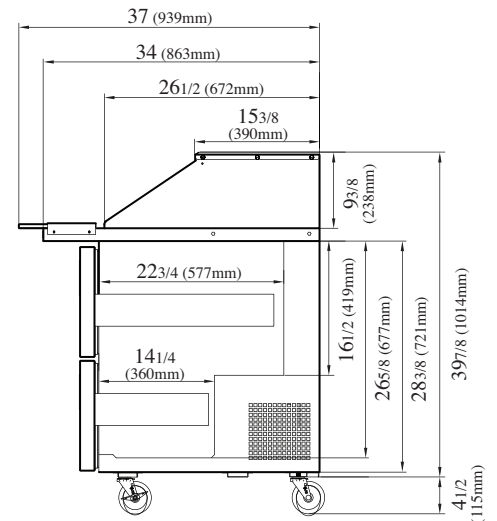

SIDE VIEW

Ver.20260219



- Turbo Air: 800-627-0032
- Bake Tech Innovation: 800-500-3519
- Warranty: 800-381-7770
- AC: 888-900-1002



Continued product development may necessitate specification changes without notice.